

ශ්‍රී ලංකා විභාග දෙපාර්තමේන්තුව ශ්‍රී ලංකා විභාග දෙපාර්තමේන්තුව ශ්‍රී ලංකා විභාග දෙපාර්තමේන්තුව ශ්‍රී ලංකා විභාග දෙපාර්තමේන්තුව ශ්‍රී ලංකා විභාග දෙපාර්තමේන්තුව  
 இலங்கைப் பரீட்சைத் திணைக்களம் இலங்கைப் பரීட்சைத் திணைக்களம் இலங்கைப் பரීட்சைத் திணைக்களம் இலங்கைப் பரීட்சைத் திணைக்களம் இலங்கைப் பரීட்சைத் திணைக்களம்  
 Department of Examinations, Sri Lanka Department of Examinations, Sri Lanka Department of Examinations, Sri Lanka Department of Examinations, Sri Lanka Department of Examinations, Sri Lanka  
 ශ්‍රී ලංකා විභාග දෙපාර්තමේන්තුව ශ්‍රී ලංකා විභාග දෙපාර්තමේන්තුව ශ්‍රී ලංකා විභාග දෙපාර්තමේන්තුව ශ්‍රී ලංකා විභාග දෙපාර්තමේන්තුව ශ්‍රී ලංකා විභාග දෙපාර්තමේන්තුව  
 இலங்கைப் பரීட்சைத் திணைக்களம் இலங்கைப் பரීட்சைத் திணைக்களம் இலங்கைப் பரීட்சைத் திணைக்களம் இலங்கைப் பரීட்சைத் திணைக்களம் இலங்கைப் பரීட்சைத் திணைக்களம்  
 Department of Examinations, Sri Lanka Department of Examinations, Sri Lanka Department of Examinations, Sri Lanka Department of Examinations, Sri Lanka Department of Examinations, Sri Lanka

අධ්‍යයන පොදු සහතික පත්‍ර (උසස් පෙළ) විභාගය, 2022(2023)  
 கல்விப் பொதுத் தராதரப் பத்திர (உயர் தர)ப் பரீட்சை, 2022(2023)  
 General Certificate of Education (Adv. Level) Examination, 2022(2023)

තොරතුරු හා සන්නිවේදන තාක්ෂණය II  
 தகவல், தொடர்பாடல் தொழினுட்பவியல் II  
 Information & Communication Technology II

20 E II

පැය තුනයි  
 மூன்று மணித்தியாலம்  
 Three hours

අමතර කියවීමේ කාලය - මිනිත්තු 10 යි  
 மேலதிக வாசிப்பு நேரம் - 10 நிமிடங்கள்  
 Additional Reading Time - 10 minutes

Use additional reading time to go through the question paper, select the questions you will answer and decide which of them you will prioritise.

Index No. : .....

### Important:

- \* This question paper consists of 14 pages.
- \* This question paper comprises of two parts, Part A and Part B. The time allotted for both parts is three hours.
- \* Use of calculators is not allowed.

### PART A – Structured Essay: (pages 2 - 8)

- \* Answer all the questions on this paper itself. Write your answers in the space provided for each question. Note that the space provided is sufficient for your answers and that extensive answers are not expected.

### PART B – Essay: (pages 9 - 14)

- \* This part contains six questions, of which, four are to be answered. Use the papers supplied for this purpose.
- \* At the end of the time allotted for this paper, tie the two parts together so that Part A is on top of Part B before handing them over to the Supervisor.
- \* You are permitted to remove only Part B of the question paper from the Examination Hall.

### For Examiners' Use Only

#### For the Second Paper

Part	Question No.	Marks
A	1	
	2	
	3	
	4	
B	5	
	6	
	7	
	8	
	9	
	10	
Total		

#### Final Marks

In numbers	
In words	

#### Code Number

Marking Examiner 1	
Marking Examiner 2	
Marks checked by:	
Supervised by:	

**Part A – Structured Essay**  
*Answer all four questions on this paper itself.*

Do not  
write  
in this  
column

1. (a) Draw the expected output of the following HTML code segment when rendered by a web browser.

```
<html>
<body>
<table border=1>
  <tr> <th>Designation</th> <th> Contact Telephone Numbers </th> </tr>
  <tr> <td rowspan=2> Principal</td> <td> 061-2223211 </td> </tr>
  <tr> <td> 067-5557772</td> </tr>
  <tr> <td> Vice Principal</td> <td> 061-5557771 </td> </tr>
  <tr> <td colspan=2> Common Phone Number: 019-2233445</td> </tr>
</table>
</body>
</html>
```

**Note:** Consider the following dotted line box as the display area of the browser.

- (b) Rewrite the following HTML code by applying internal CSS with grouping selectors.

```
<html>
<head> <title>Cascading Style Sheets</title> </head>
<body>
<h1 style="color:blue;text-align:center"> Introduction to Cascading Style Sheets</h1>
<h2 style="color:blue"> CSS can be applied to html documents in three different ways.</h2>
</body>
</html>
```

(c) Consider the HTML form given in Figure 1 rendered by a web browser.

Do not  
write  
in this  
column

Figure 1

The relevant HTML code (incomplete) is given below. Fill the blanks in it in order to get the output shown in Figure 1.

```
<html>
<head>Registration Form</head>
<body>
<h3>Registration for Examination</h3>
<form ..... = "process.php" ..... = "post">
<div> ..... <input ..... = "....." ..... = "name"> </div>
<p>
<div>
  Select Examination Module: <p>
    <input ..... = "....." ..... = "module[]" ..... = "ICT" /> ..... <br>
    <input ..... = "....." ..... = "module[]" ..... = "English" /> ..... <br>
    <input ..... = "....." ..... = "module[]" ..... = "IQ" /> ..... <br>
  </div>
  <br>
  <div>
    Preferred Medium:
    <input ..... = "....." ..... = "language" ..... = "Sinhala" ..... /> Sinhala
    <input ..... = "....." ..... = "language" ..... = "Tamil" /> Tamil
    <input ..... = "....." ..... = "language" ..... = "English" /> English
  </div>
  <div>
    <br>
    Select Test Center:
    <..... name="Center">
      <..... = "Colombo" selected>..... </.....>
      <..... = "Matara"> ..... </.....>
      <..... = "Jaffna"> ..... </.....>
    </..... >
  </div>
  <br>
  <input type="submit" name="submit" value="submit" >
</form>
</body>
</html>
```

- (d) The process.php script is invoked after submitting the above form in part (c). After submitting the form, it is required to display the name, medium and test center. Complete the following PHP code segment (process.php) to fulfil this requirement.

Do not  
write  
in this  
column

```
<?php
if ($_SERVER["REQUEST_METHOD"] == "POST") {
    $name = $_.....["....."];
    $medium = $_.....["....."];
    $center = $_.....["....."];
}

echo "<h2> Your Input:</h2>";
echo $.....; echo "<br>";
echo $.....; echo "<br>";
echo $.....; echo "<br>";
?>
```

2. (a) Fill the blanks in the following statements by selecting the most suitable items from the given list.

A few of your friends who study ICT for A/L at your school decided to improve the school library by introducing an online library management system. Assuming they know the requirements, they started system development as the first step and completed a system which includes a mobile user interface and a database. After completing the system, they met the school principal and the library staff for a demonstration and possible deployment of their system. Their completed solution requires a computer at each classroom to access the library system.

At the meeting they got to know that the library already has a database to keep the records of books and borrowings, and it is functioning well with a simple user interface.

**List:** {preliminary investigation, technical feasibility, economic feasibility, operational feasibility, organizational feasibility, problem definition, system deployment}

- (i) This team of students could have found out about the existing library system at the beginning if they did not skip the .....
- (ii) The school principal refuses to accept this proposed solution due to resource constraints and the limited benefits compared to the investment. This indicates the solution developed by students lacks .....
- (iii) The library staff says that they will accept and use this demonstrated system only if the existing database is used as a part of the new solution. This indicates the solution developed by students lacks .....

(b) The following is a labelled data flow diagram (DFD) to represent purchasing activities at a furniture shop.

Do not write in this column

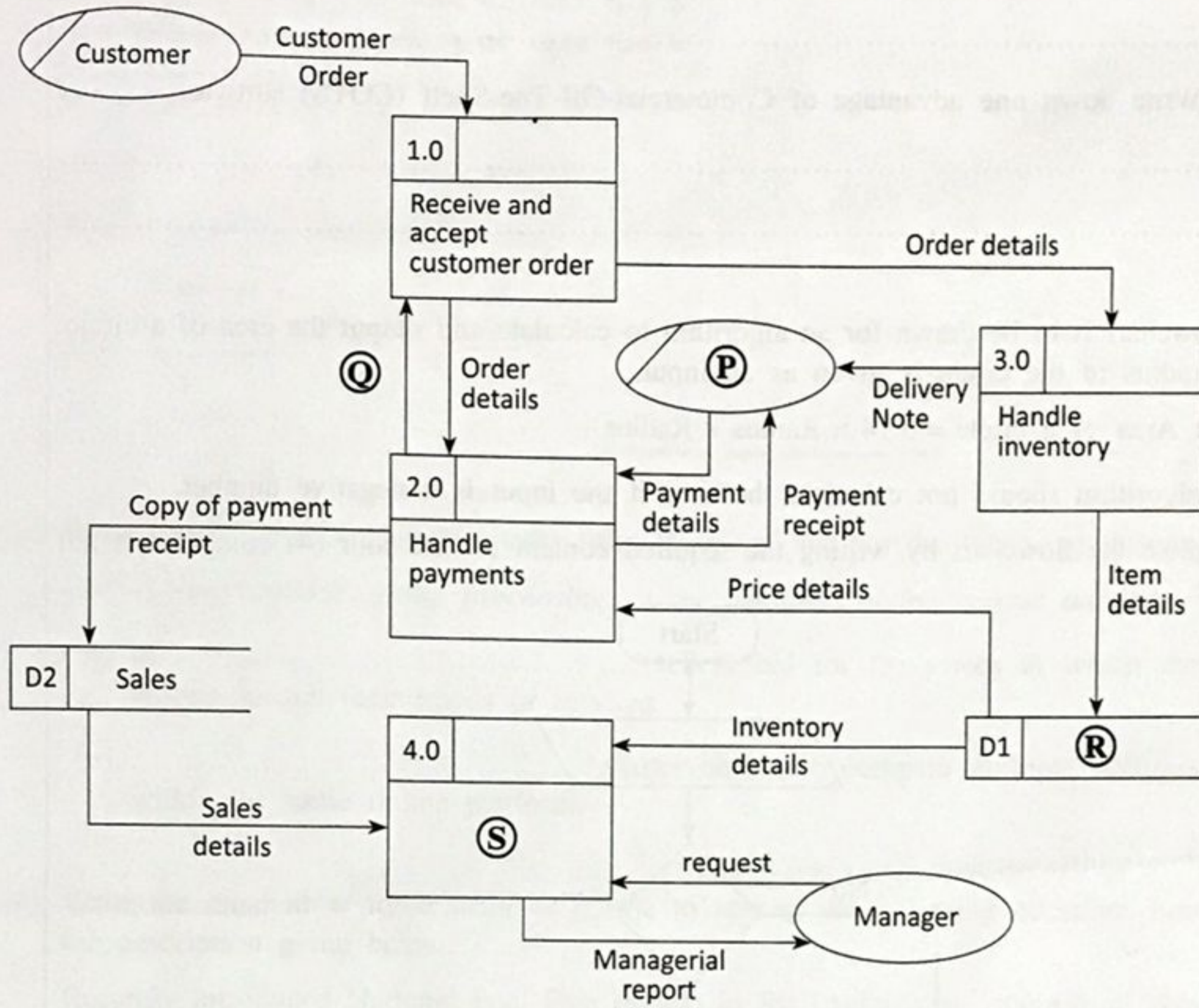

**Note:** symbol denotes duplicated external entities.

(i) Write down the most suitable item for P, Q, R and S by selecting from the given list.

**List:** {Generate reports, Inventory, Copy of payment receipt, Customer, Customer details, Item details, Manager, Sales person, Sales}

- P - ..... Q - .....
- R - ..... S - .....

(ii) How many processes, external entities and data stores are shown in the above diagram?

- No. of Processes : .....
- No. of External entities : .....
- No. of Data stores : .....

Do not write in this column

(c) (i) Write down **one** difference between parallel deployment and pilot deployment.

.....  
.....

(ii) Write down **one** advantage of Commercial-Off-The-Shelf (COTS) software.

.....  
.....



3. (a) A flowchart is to be drawn for an algorithm to calculate and output the area of a circle. The radius of the circle is given as an input.

**Note:** Area of a circle =  $3.14 \times \text{Radius} \times \text{Radius}$

The algorithm should not calculate the area if the input is a negative number.

Complete the flowchart by writing the required content for the four (4) components left blank.

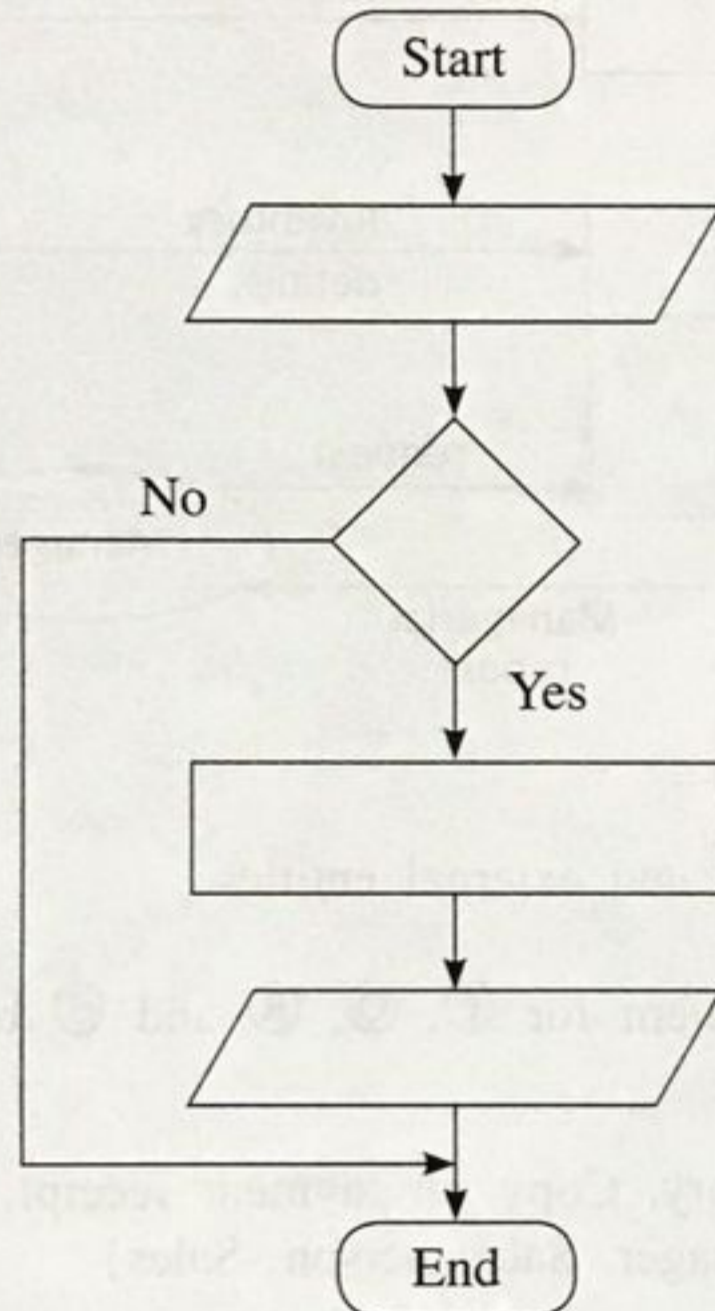

(b) What is the output of the following Python code?

```

S = "Advanced level"
S1 = " "
for c in S :
    if c in ( "a" , "e" , "i" , "o" , "u" ) :
        pass
    else:
        S1 = S1 + c
print (S1)
  
```

.....

(c) What code line(s) in part (b) is/are to be removed to get 'aeee' as the output?

.....  
.....  
.....

(d) Fill in the blank spaces of the following Python code assuming that the purpose of the code is to copy the content of a text file (A) to another text file (B).

```

A = input("Enter the name of text file A")
B = input("Enter the name of text file B")

f1 = ..... (A, ..... )
f2 = ..... (B, ..... )

for line in ..... :
    f2.write (.....)

f1. ....
f2. ....

```

Do not write in this column

4. (a) Write down the most suitable items from the given list for the following statements.

List: {e-marketplace, group purchasing, online auctions, online reverse auctions}

- (i) In ....., sellers bid for the prices at which they are willing to sell their goods or services.
- (ii) ..... allows buyers to compare multiple online sellers within the same online platform.

(b) Write the most appropriate word or phrase to answer the following questions based on the description given below.

Recently introduced National Fuel Pass system in Sri Lanka is an example of how ICT can be used to overcome national challenges successfully. It is observed that for a given week, the maximum server hardware resource utilization happens only for a short period (e.g., few hours) and the rest of the time the system operates at a very low resource demand.

(i) One of the views on resource provision is to purchase computer hardware permanently considering the maximum demand. What is the main **disadvantage** with this approach?

.....  
.....

(ii) What is the alternative solution to overcome the disadvantage mentioned in (b)(i) above, while satisfying the maximum resource demand instances?

.....

Do not write in this column

(c) The steps in the fetch-execute cycle are as follows:

1. The .....<sup>Ⓟ</sup>..... is loaded with the memory address of the relevant instruction of the program.
2. The instruction is loaded into the instruction register.
3. The instruction present in the instruction register is decoded.
4. The control unit of the CPU passes the decoded instruction as a sequence of control signals to the relevant .....<sup>Ⓠ</sup>..... of the CPU.
5. The program counter is changed to point to the next instruction.
6. Steps from Step 2 are repeated.

Select the most suitable items to replace the labels <sup>Ⓟ</sup> and <sup>Ⓠ</sup> from the following list.

List: {file, functional unit, instruction, memory, page, program counter}

<sup>Ⓟ</sup> - .....

<sup>Ⓠ</sup> - .....

(d) (i) Complete the truth table for the given logic circuit.

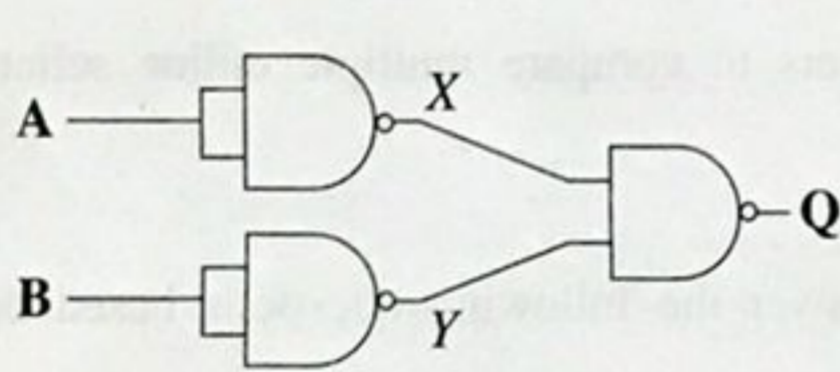

A	B	X	Y	Q
0	0			
0	1			
1	0			
1	1			

(ii) What is the basic logic gate that has the above truth table (with inputs A, B and the output Q)?

.....

(e) The diagram below shows the OSI reference model and its mapping to the TCP/IP model. Write the correct names of the layers indicated by the labels P, Q, R, S, T and U.

OSI Reference Model	TCP/IP Model
P	S
Presentation Layer	
Session Layer	
Transport Layer	T
Q	U
R	Network Access Layer
Physical Layer	

P .....

Q .....

R .....

S .....

T .....

U .....

\*\*



ශ්‍රී ලංකා විභාග දෙපාර්තමේන්තුව ශ්‍රී ලංකා විභාග දෙපාර්තමේන්තුව ශ්‍රී ලංකා විභාග දෙපාර්තමේන්තුව ශ්‍රී ලංකා විභාග දෙපාර්තමේන්තුව ශ්‍රී ලංකා විභාග දෙපාර්තමේන්තුව  
 இலங்கைப் பரீட்சைத் திணைக்களம் இலங்கைப் பரීட்சைத் திணைக்களம் இலங்கைப் பரීட்சைத் திணைக்களம் இலங்கைப் பரීட்சைத் திணைக்களம் இலங்கைப் பரීட்சைத் திணைக்களம்  
 Department of Examinations, Sri Lanka Department of Examinations, Sri Lanka Department of Examinations, Sri Lanka Department of Examinations, Sri Lanka Department of Examinations, Sri Lanka  
 ශ්‍රී ලංකා විභාග දෙපාර්තමේන්තුව ශ්‍රී ලංකා විභාග දෙපාර්තමේන්තුව ශ්‍රී ලංකා විභාග දෙපාර්තමේන්තුව ශ්‍රී ලංකා විභාග දෙපාර්තමේන්තුව ශ්‍රී ලංකා විභාග දෙපාර්තමේන්තුව  
 இலங்கைப் பரීட்சைத் திணைக்களம் இலங்கைப் பரීட்சைத் திணைக்களம் இலங்கைப் பரීட்சைத் திணைக்களம் இலங்கைப் பரීட்சைத் திணைக்களம் இலங்கைப் பரීட்சைத் திணைக்களம்  
 Department of Examinations, Sri Lanka Department of Examinations, Sri Lanka Department of Examinations, Sri Lanka Department of Examinations, Sri Lanka Department of Examinations, Sri Lanka

අධ්‍යයන පොදු සහතික පත්‍ර (උසස් පෙළ) විභාගය, 2022(2023)  
 கல்விப் பொதுத் தராதரப் பத்திர (உயர் தர)ப் பரீட்சை, 2022(2023)  
 General Certificate of Education (Adv. Level) Examination, 2022(2023)

කොරකුරු හා සන්නිවේදන තාක්ෂණය II  
 தகவல், தொடர்பாடல் தொழினுட்பவியல் II  
 Information & Communication Technology II

20 E II

Part B

\* Answer any four questions only.

5. (a) Consider the logic circuit shown in the following figure in which P, Q and R are the inputs and Z is the output.

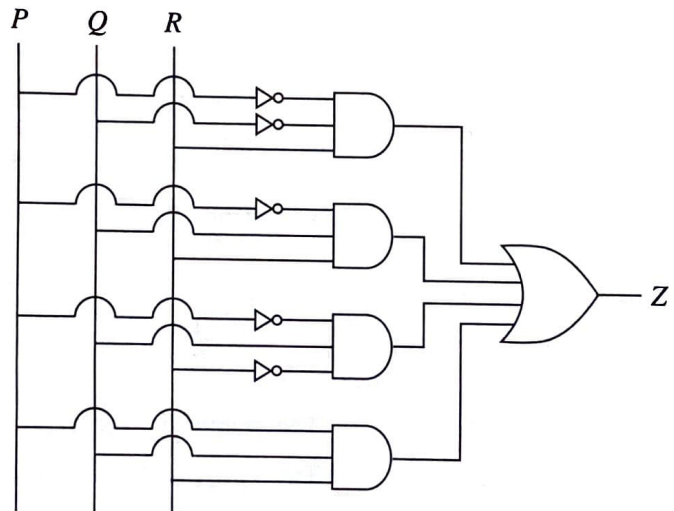

- (i) Draw the complete truth table for the above circuit.
- (ii) Complete the Karnaugh map relevant to the above circuit according to the following format.

		PQ			
		00	01	11	10
R	0				
	1				

- (iii) Using the Karnaugh map, derive the most simplified sum-of-products expression for the output Z. Show the loops clearly on the Karnaugh map.
- (b) (i) Using Boolean algebra, show that the Boolean expression  $\bar{A}BC + A\bar{B}C + ABC\bar{C} + ABC$  is equivalent to  $BC + AC + AB$ .
- (ii) Draw a logic circuit for the above **simplified** expression in (b)(i) by only using OR and AND gates.
- (iii) Draw a logic circuit for the above **simplified** expression in (b)(i) by only using NAND gates.

6. (a) Write down the most suitable terms to replace the blanks labelled (P) to (U) in the following paragraph related to data encryption.

There are two types of encryption techniques used namely, *symmetric key encryption* and *asymmetric key encryption*. In ..... (P) ..... key encryption, the same key is used for encrypting and decrypting the information. In this scheme, to exchange information, users must share a ..... (Q) ..... key among themselves. In ..... (R) ..... key encryption, different keys are used for encrypting and decrypting the information. In this technique, users usually have a pair of dissimilar keys known as a ..... (S) ..... key and a ..... (T) ..... key. When one key is used for encryption, the other key can decrypt the ..... (U) ..... back to the original plain text.

- (b) Suppose that the ABC Company has received the 192.248.154.0/25 IP address block to be distributed among its four departments.

It is required to subnet the above IP address block to satisfy the following requirements. Assume that each department is located in a separate building.

Subnet Number	Department Name	Number of Computers
S001	Accounts	30
S002	Sales	28
S003	Service	18
S004	Administration	24

- (i) Write the first address and the last address in the given address block.  
(ii) Write the subnet mask of the given address block in dotted decimal notation.  
(iii) How many host bits are needed to create the required number of subnets?  
(iv) Once subnetting is done, fill the following table.

Subnet Number	Network Address	Subnet mask	First usable IP address	Last usable IP address	Broadcast Address
S001					
S002					
S003					
S004					

- (c) (i) Write **one** difference between User Datagram Protocol (UDP) and Transmission Control Protocol (TCP) transport layer protocols.  
(ii) Write **two** main functions of a router.
- (d) (i) What is the functionality of a Domain Name System (DNS) server?  
(ii) What is the functionality of a Dynamic Host Configuration Protocol (DHCP) server?

7. (a) An IoT setup to water a plant in a greenhouse is shown in Figure 1. A mobile application is used to operate the water-releasing tap. As shown, the setup includes a sensor, a controller, and a microcontroller (Arduino Board) with a communication module.

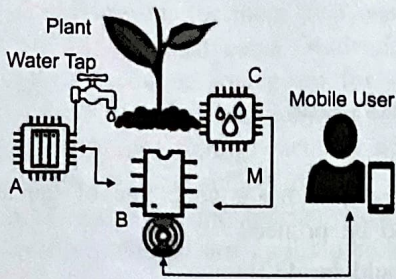

Figure 1

- (i) Match the IoT components labelled as A, B and C to components described in the scenario.  
 (ii) Explain the reason why the arrow M is shown in a single direction.

- (b) The moisture sensor provides 10 levels of moisture intensity with 1 being “the driest” and 10 being “the wettest”; 8 is the desired level to be maintained. The algorithm on the right can be used to automate the task of opening the tap when the soil is dry and to stop the water flow when enough watering is done. Write down the most suitable entries for the places labelled X, Y and Z. [Note – While (true) block represents the continuous loop function in Arduino]

```

While (true){
  Read Moisture Level as M_L
  If [X]
    If Tap Closed
      Then [Y]
    End if
  Else
    If Not Tap Closed
      Then [Z]
    End if
  End if
}
  
```

- (c) What could be monitored in the greenhouse using an LDR sensor?

- (d) A multi-agent system is proposed for this greenhouse (Figure 2). In this system the images that are captured using a mobile phone are stored in the plant database. The multi-agent system works as follows:

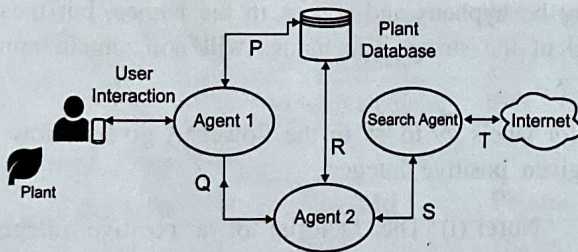

Figure 2

- Agent 1 handles the user interactions, user access to data, and triggers Agent 2.
- Agent 2 processes the images, identifies anomalies if any, and triggers Search Agent if needed.
- Search Agent searches relevant information from the Internet, feeds the search results to Agent 2 who updates the database after processing, and notifies Agent 1 if an alert is to be raised.

- (i) In the given scenario, who is/are the self-autonomous agent(s)?  
 (ii) The interaction P involves saving plant details in the database and retrieving those for Agent 1. The interaction R involves reading the database and writing search results to the database. Explain the interactions Q and S.  
 (iii) After long-term use of the system, it was decided to remove Search Agent assuming that the database contains all the information needed. Write down the main disadvantage of this removal.
- (e) The owner has started an online shop to sell the harvest from this greenhouse to buyers who are nearby.
- State one advantage of limiting sales to the community nearby the greenhouse.
  - State an alternative payment method that can be used until an online payment facility is setup.
  - He cultivated tomatoes and sells salted dried tomatoes online (as a snack). This, known as value addition, gives higher profits. Give another advantage of this value-addition to his e-business.

8. (a) (i) What is the output of the following python script if 1002 is given as the input?

```
A = int(input("Enter a number:"))
B = 0
while(A > 0):
    C = A % 10
    B = B + C
    A = A // 10    # // is integer division
print(B)
```

- (ii) What would be the modification required to the  $B = B + C$  code line of the above code if the reverse of a given positive number is to be printed?  
(Example: if the input is 1234, the output should be 4321)

- (b) Assume that your class is having a party, and each student is asked to bring one food item. The class teacher has decided to make the party interesting by introducing one rule: the first and last letters of the name of the food item must match with the first and last letters of the student name.

For example, *percy* is allowed to bring *potato curry* and *prageeth* is allowed to bring *pepper fish*.

Write a Python function called Party() that takes the student name and the name of the food item as parameters. The function should return **True** or **False** to indicate whether the student is allowed to bring the food item to the party or not.

Example:

Party ("percy", "potato curry") should return **True**

Party ("fareena", "fried rice") should return **False**

**Note:** You can assume that student name and food item name are always lowercase strings and have at least two letters. There may be hyphens and spaces in the names, but these will not appear at the beginning or end of the string. The names will not contain numerals.

- (c) Write down the most suitable statements for labels (A) to (H) in the flowchart given below which is drawn to calculate the factorial of a given positive integer.

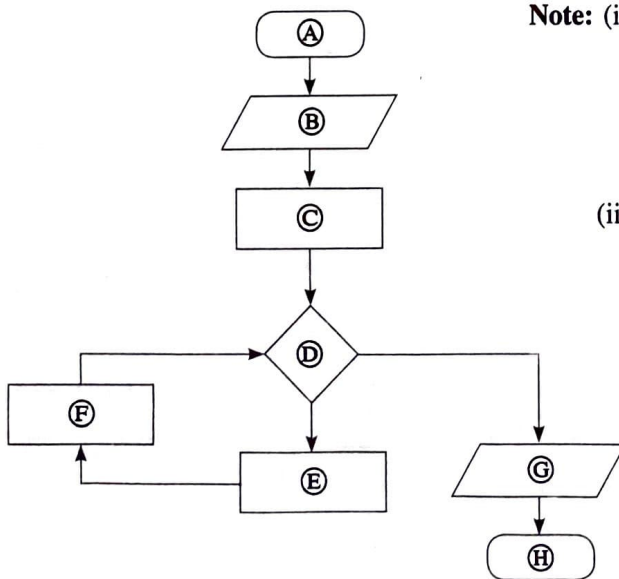

**Note:** (i) The factorial of a positive integer is defined as the product of that integer and all the integers below it. E.g. factorial of 5 is  $5 \times 4 \times 3 \times 2 \times 1 = 120$ . The factorial of 0 is defined as 1.

(ii) A process box in this flowchart may contain one or more statements.

9. (a) Draw the Entity Relationship (ER) diagram for the following scenario.

A student uses the following data to register for subjects. Each subject is represented by its subject number (subjectNumber), subject name (subjectName) and prerequisite subject. A student can register for more than one subject during a semester. Each student has a first name (studentFname), a last name (studentLname) and a unique student number (studentId). Student age (age) is required to register for subjects. Subjects are offered based on the availability of the resources. Hence some subjects will not be offered during a semester. A subject offered in a semester (subject\_offering) includes subjectNumber, year, semester, teacher identifier (teacherId), and classroom. One subject\_offering is assigned to a single teacher who is represented by a teacherId, name of the teacher (teacherName), and qualifications. Teacher can have several qualifications. Marks are awarded to students for each subject that they register.

Use only the terms from the list given below for the entities and attributes in your ER diagram. You have the freedom to choose relationship names.

List : {age, classroom, DOB, marks, qualification, semester, student, studentFname, studentId, studentLname, subject, subject\_offering, subjectName, subjectNumber, teacher, teacherId, teacherName, year}

Note: DOB – Date of Birth

- (b) Use the following **Employee**, and **Assign\_Project** denormalized tables to answer parts (i), (ii), (iii), (iv) and (v). Please note that primary key(s) of each table is(are) underlined.

**Employee**

<u>EmployeeId</u>	FullName	DOB	Salary
E001	Saman Perera	12/02/1978	140000
E002	Upul Fernando	23/05/1982	44000
E005	Chris Peris	11/08/1980	44000
E007	Kamala Gamage	08/08/1973	52000
E008	Sunil Perera	25/04/1969	115000
E011	Vipul Namal	09/02/1977	38000

**Assign\_Project**

<u>ProjectId</u>	<u>EmployeeId</u>	PName	Description
P04	E002	Sales	Implement sales management system
P04	E008	Sales	Implement sales management system
P06	E007	HRM	Implement HRM system
P07	E002	Library	Implement library management system
P09	E001	Inventory	Implement inventory management system
P09	E007	Inventory	Implement inventory management system

- (i) Write down the output of the following SQL statement:  
 SELECT Employee.FullName, Employee.Salary  
 FROM Employee, Assign\_Project  
 WHERE Assign\_Project.EmployeeId = Employee.EmployeeId;
- (ii) Write an SQL statement to display the names of the employees who are assigned to project P04.
- (iii) In which normal form does the **Assign\_Project** table exist?
- (iv) What needs to be done to convert the **Assign\_Project** table into its next normal form? Justify your answer.
- (v) Give an example SQL query where the update anomaly can occur in **Assign\_Project** table.

10.(a) A user starts a web browser on her single processor computer to go through some Python tutorials. She also starts a text editor to work on her Python program. The diagram shows how the *web browser* ( $P_W$ ) and the *text editor* ( $P_T$ ) processes run on the processor along with the *operating system* ( $P_{OS}$ ) since the time the user started the web browser. What important work related to  $P_W$  and  $P_T$  will be performed by the operating system during the time period indicated by 'O'?

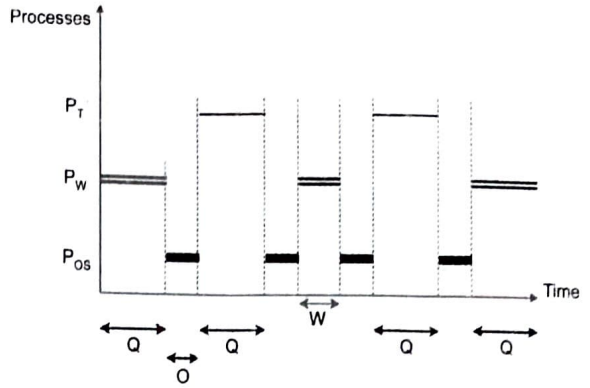

(b) Assume that the time period the operating system allocates to each process to run on the processor in a single instance is  $Q$ . Explain why  $W$  (the time period the web browser process runs at the second instance) is less than  $Q$  as shown in the graph.

(c) Assume that we have a computer that can use 16-bit virtual addresses from 0 up to 64 K. Assume further that this computer has only 32 KB of physical memory and that the page size in this computer is 4 KB.

The above 16-bit virtual address is made up of the *bits of the page number* followed by *offset bits*.

User runs a particular program having a size of 32 KB on this computer. A few selected fields of the page table of that process at a particular time are shown in the figure below.

Page number	Frame number	Present/absent
0	011	1
1	101	1
2	000	0
3	000	0
4	000	0
5	000	0
6	000	0
7	000	0

**Notes:**

- The frame number is indicated in binary.
- The virtual addresses on page 0 are from 0 to 4095 and on page 1 are from 4096 to 8191 and so on.
- The Present/absent bit indicates the validity of the entry. If this bit is 1, the entry is valid and can be used. If it is 0, then the relevant virtual page is not in physical memory.

Assume that in the above process the virtual address 0001 0000 0000 0011 is wanted. Is that page available in physical memory? If your answer is 'yes', then write down the 15-bit physical address that the above virtual address will be mapped into. If your answer is 'no', then write down the actions that the operating system will take on behalf of that process for the said requirement.

- (d) Give **two** reasons as to why a page of a process may not be in physical memory.
- (e) Explain how the operating system could find the blocks of a file when the files are stored on a hard disk using
- contiguous allocation and
  - index allocation.
- (Hint: the use of the directory entry)